

Top-level Schematic1

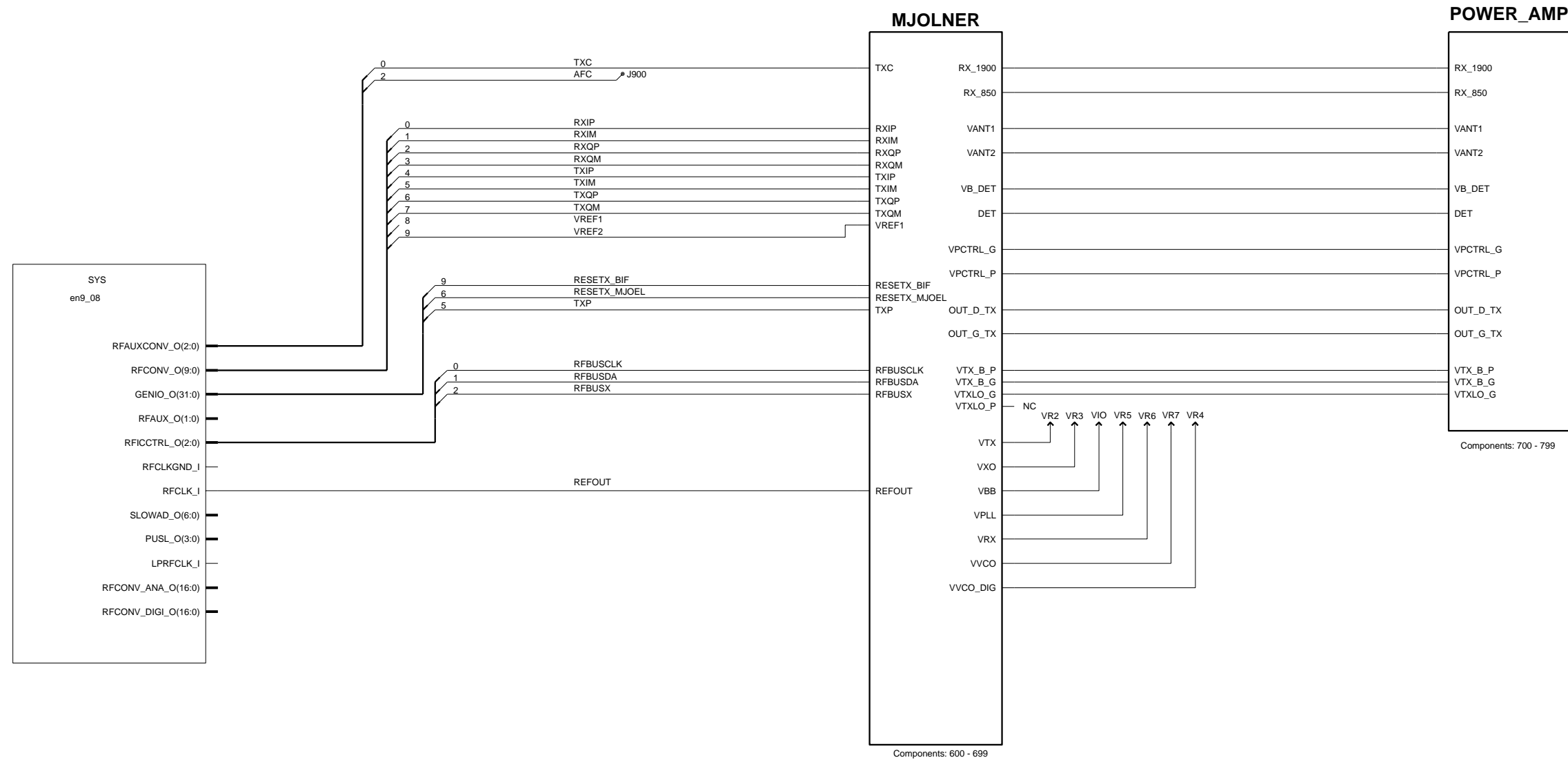

Shield Sheet

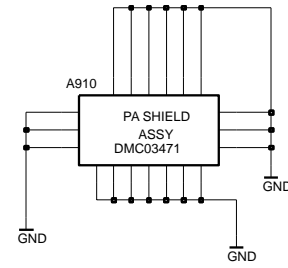
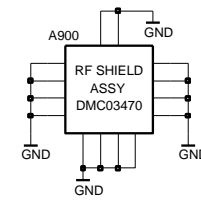
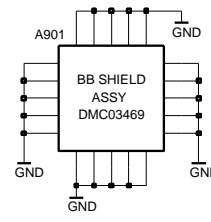
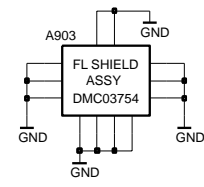
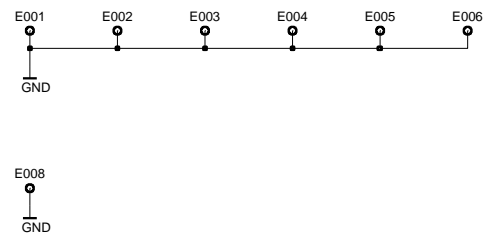

DCT4 Common Baseband

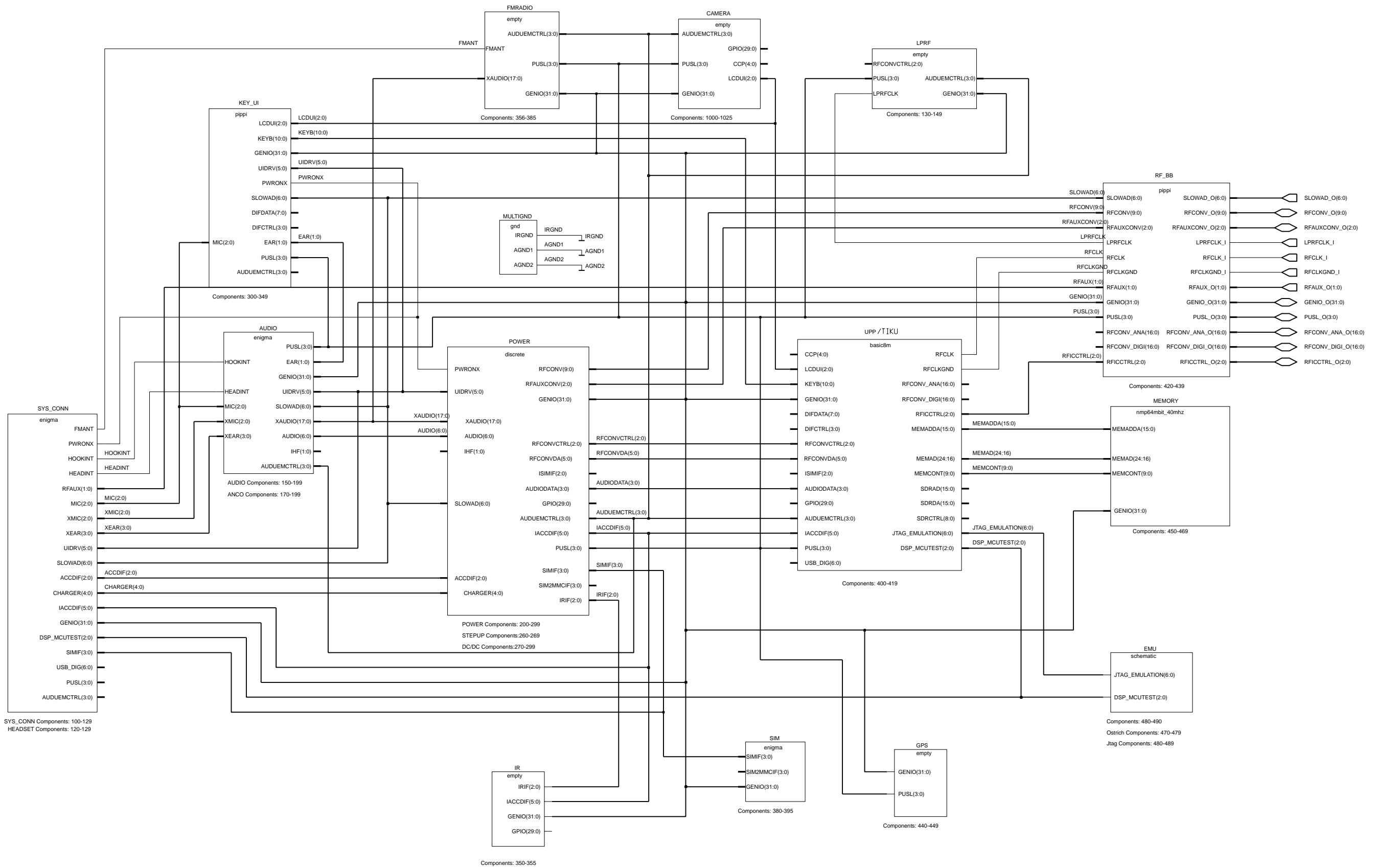

Discrete Power Supply

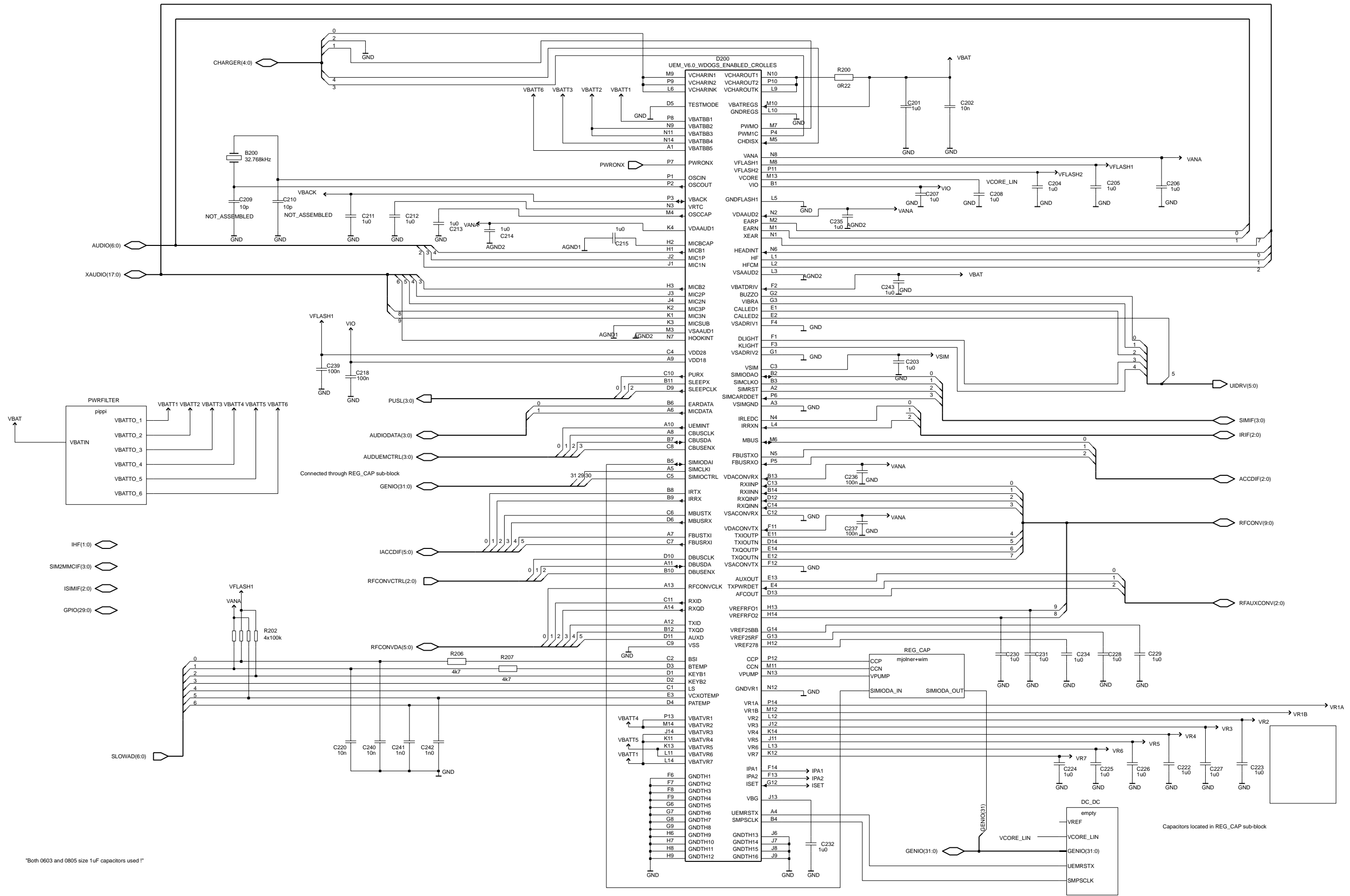

DC/DC Converter

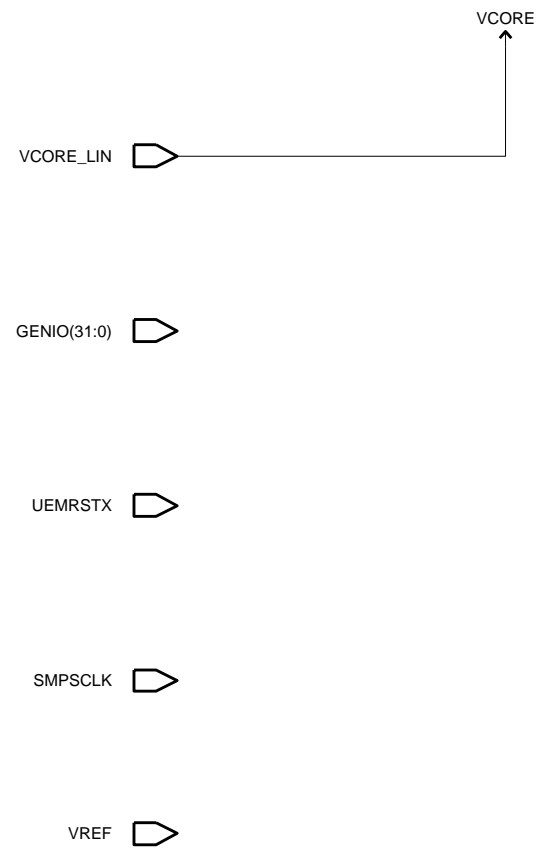

DCT4 Power Supply

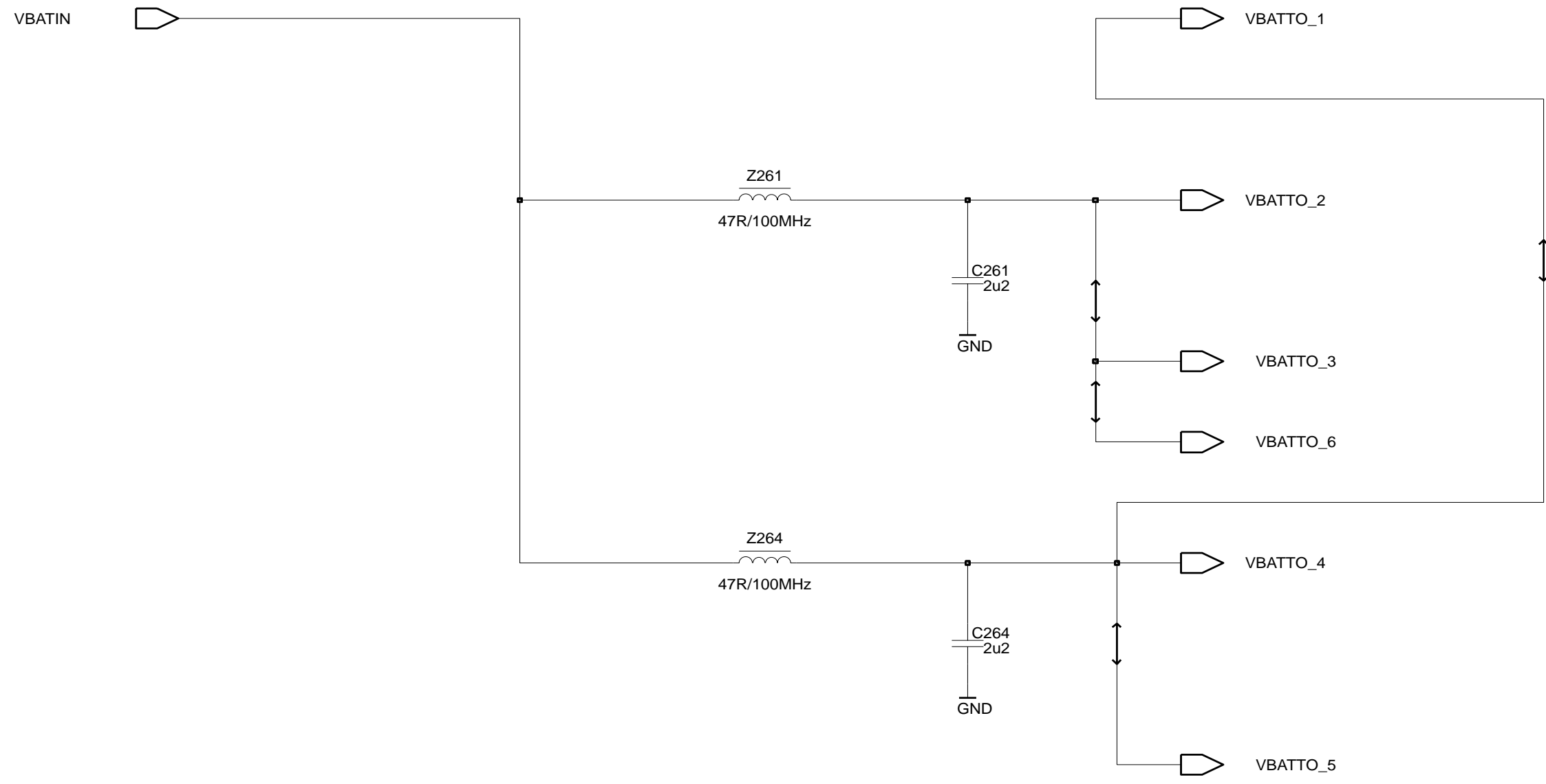

DCT4 Common Baseband

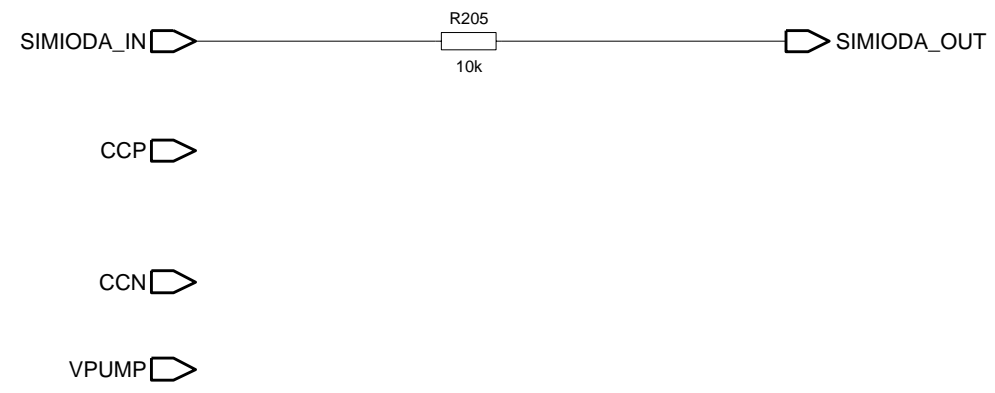

System Connector

For After Sales

X101  
 1  
 2  
 3  
 4  
 VBATTRF  
 GND  
 \*Janette Battery I/F\*

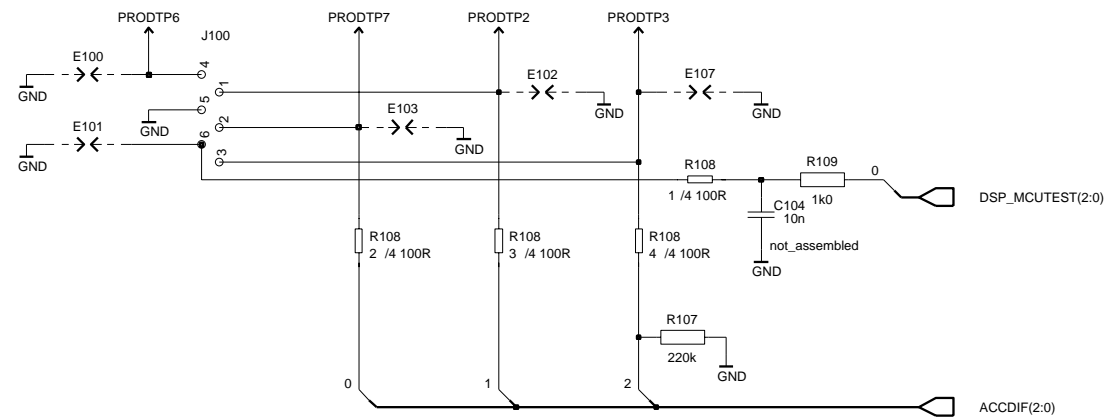
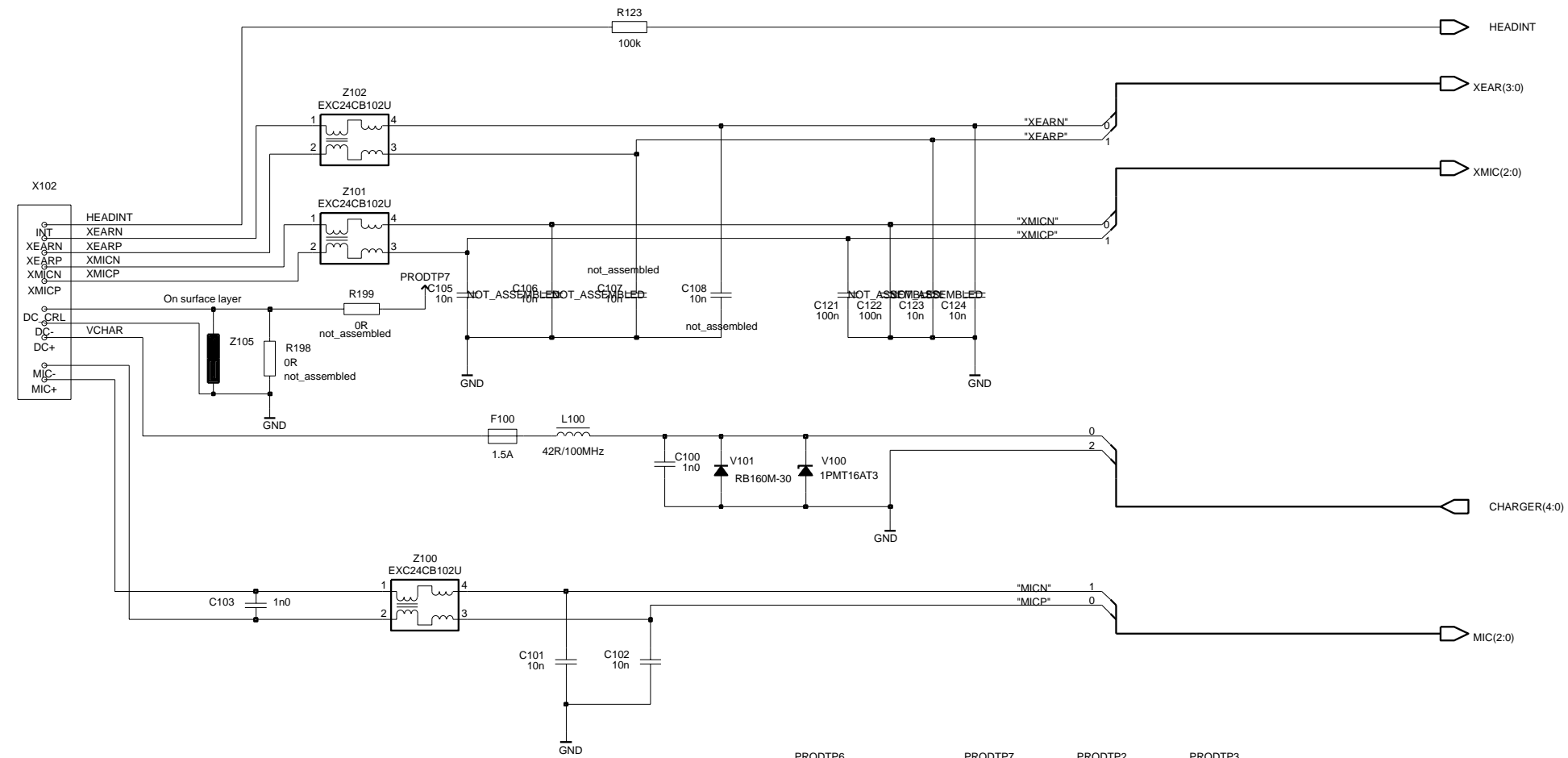

- UIDRV(5:0)
- IACCDIF(5:0)
- RFAUX(1:0)
- PWRONX
- SIMIF(3:0)
- HOOKINT
- GENIO(31:0)
- FMANT
- USB\_DIG(6:0)
- PUSL(3:0)
- AUDUECTRL(3:0)



### Test and Emulator Interface



### Connector-based Ostrich Test Interface

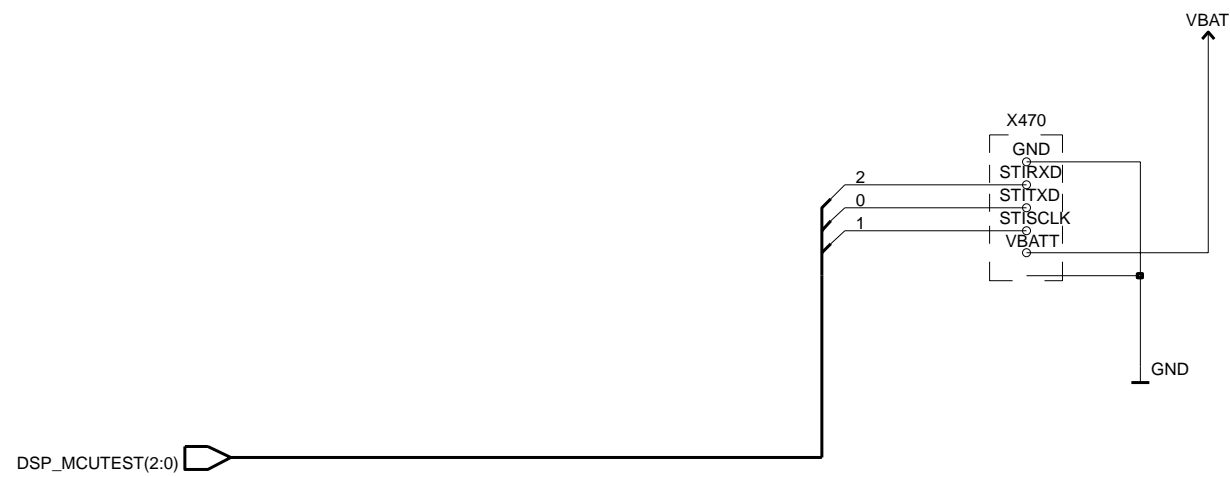

User Interface Clover Key Targets

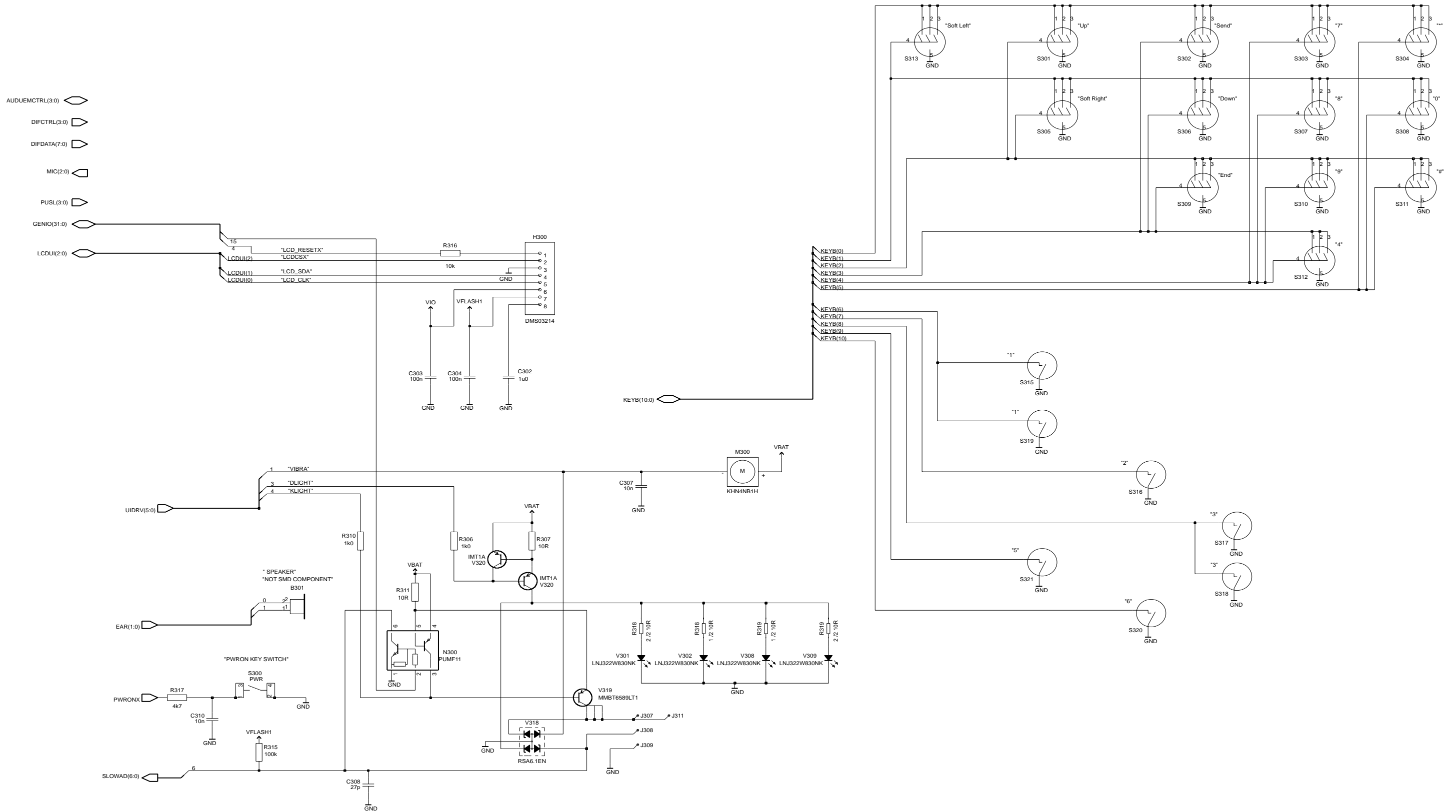

UPP 8M Implementation

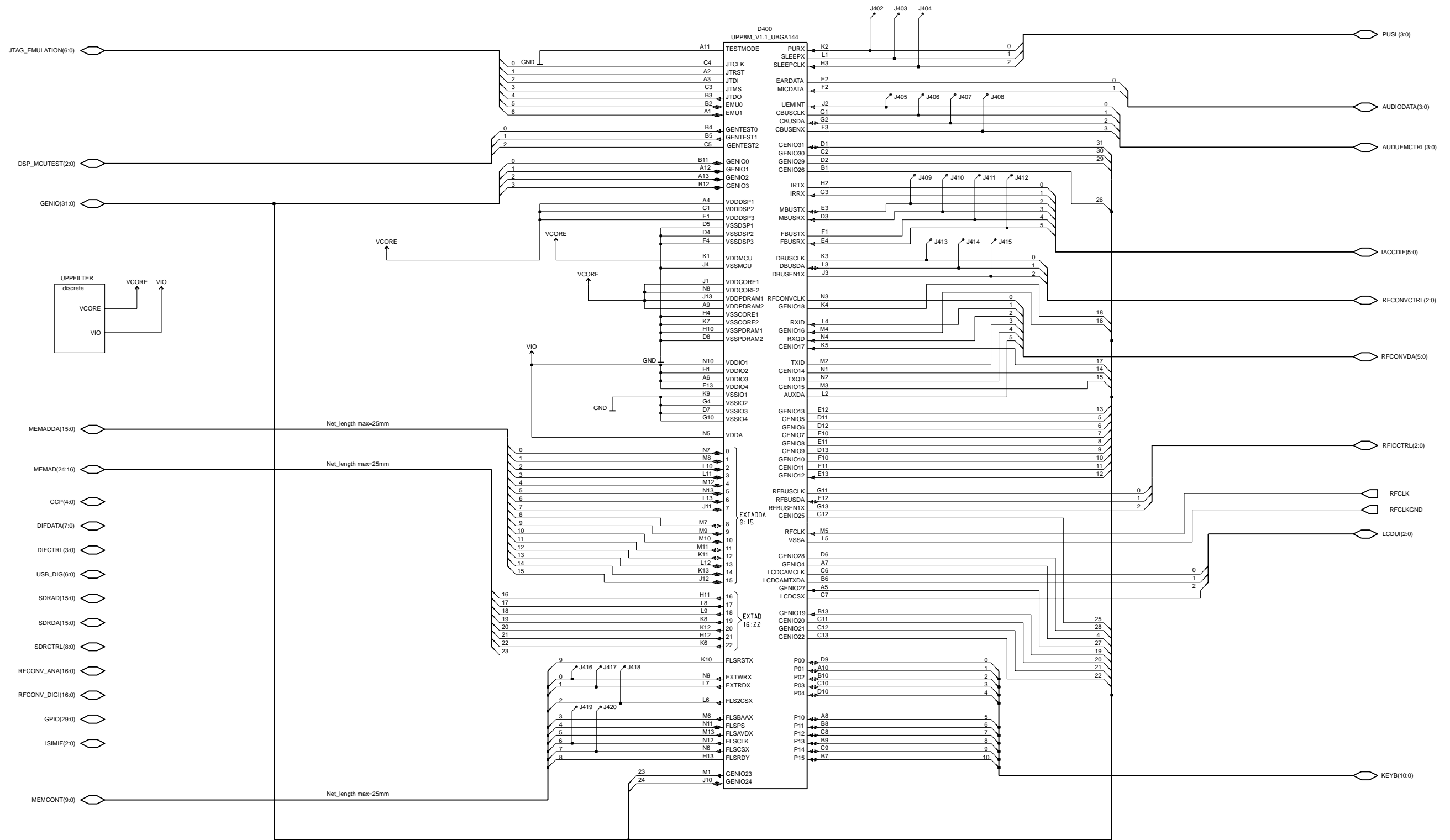

Discrete Decoupling Capacitors for UPP

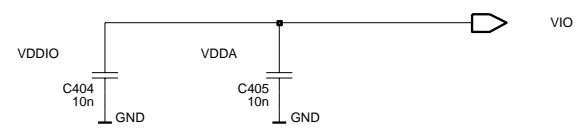
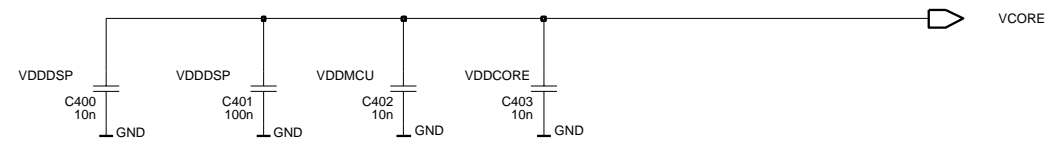

Flash Memory 64 Mbit

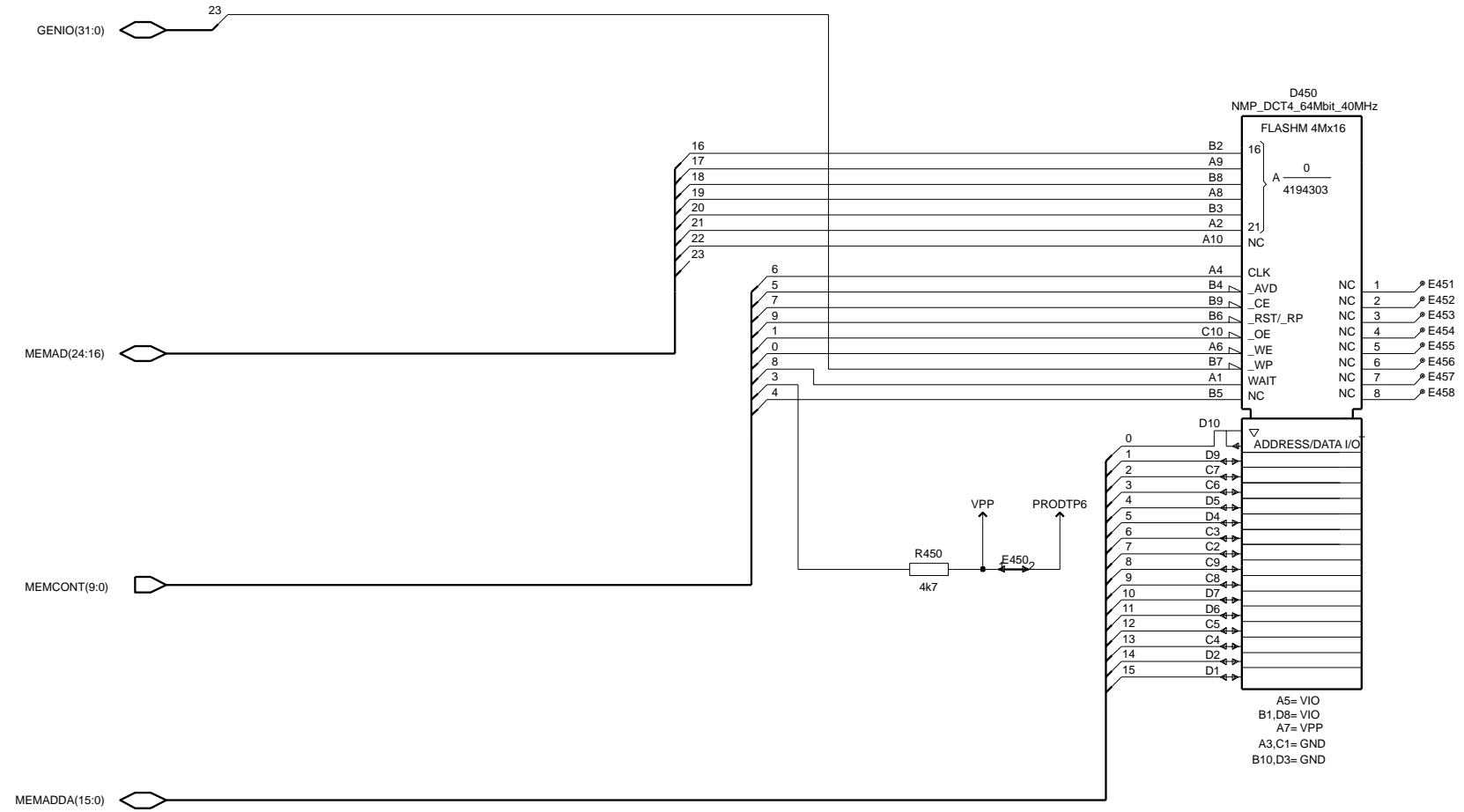
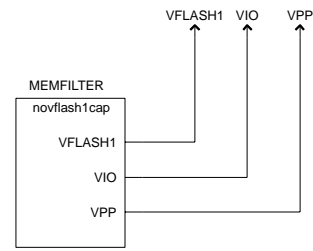

Discrete Capacitors for Memory Without VFlash

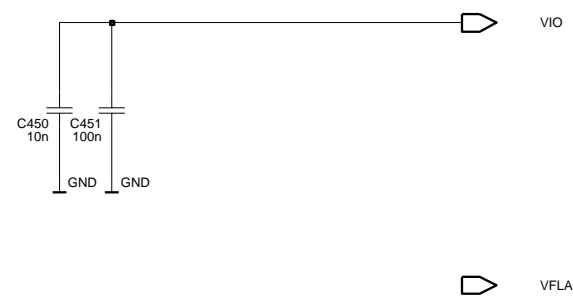

RF/BB Interface

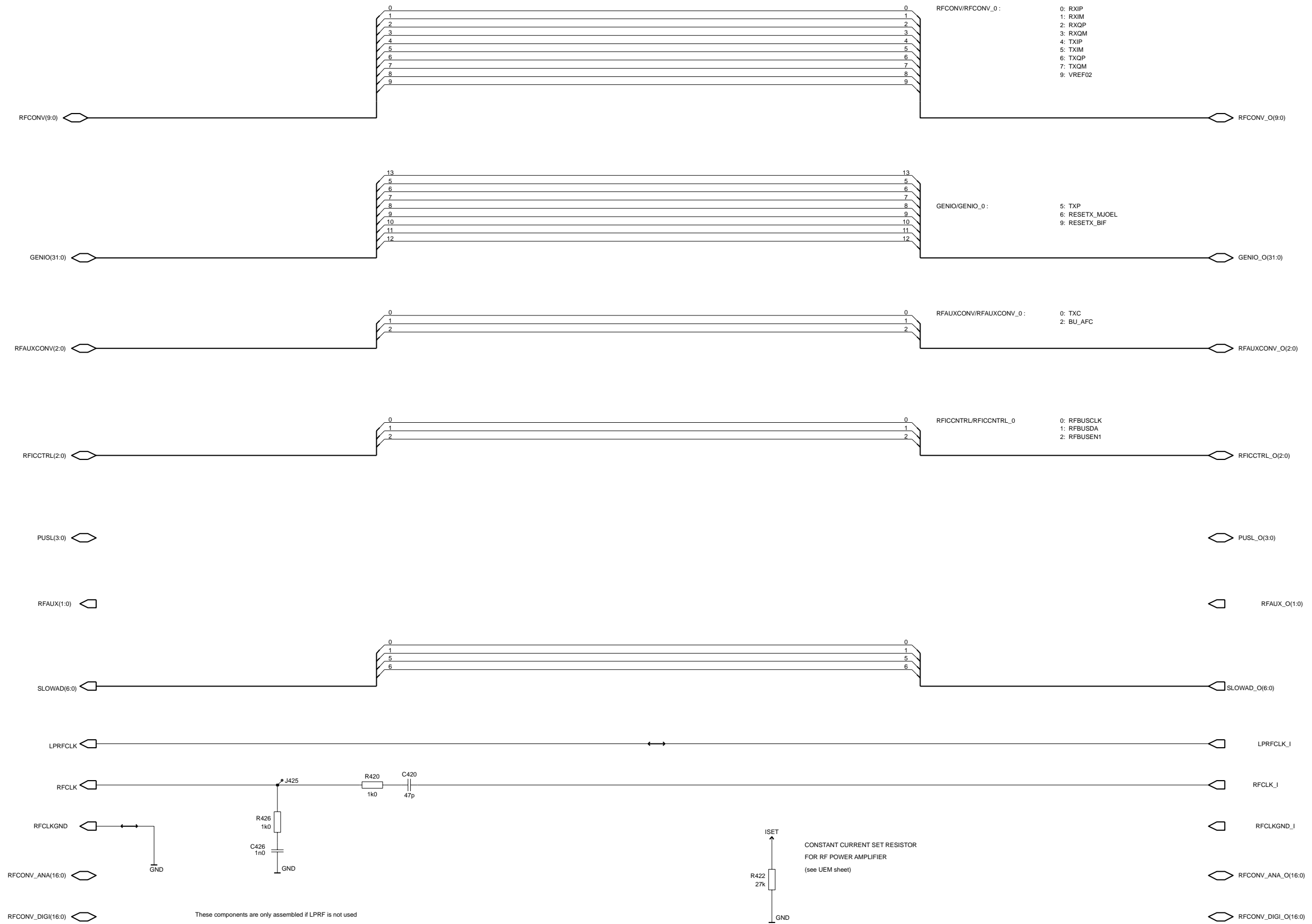

Audio Interface

- PUSL(3:0)
- UIDRV(5:0)
- HOOKINT
- AUDUEMCTRL(3:0)
- IHF(1:0)

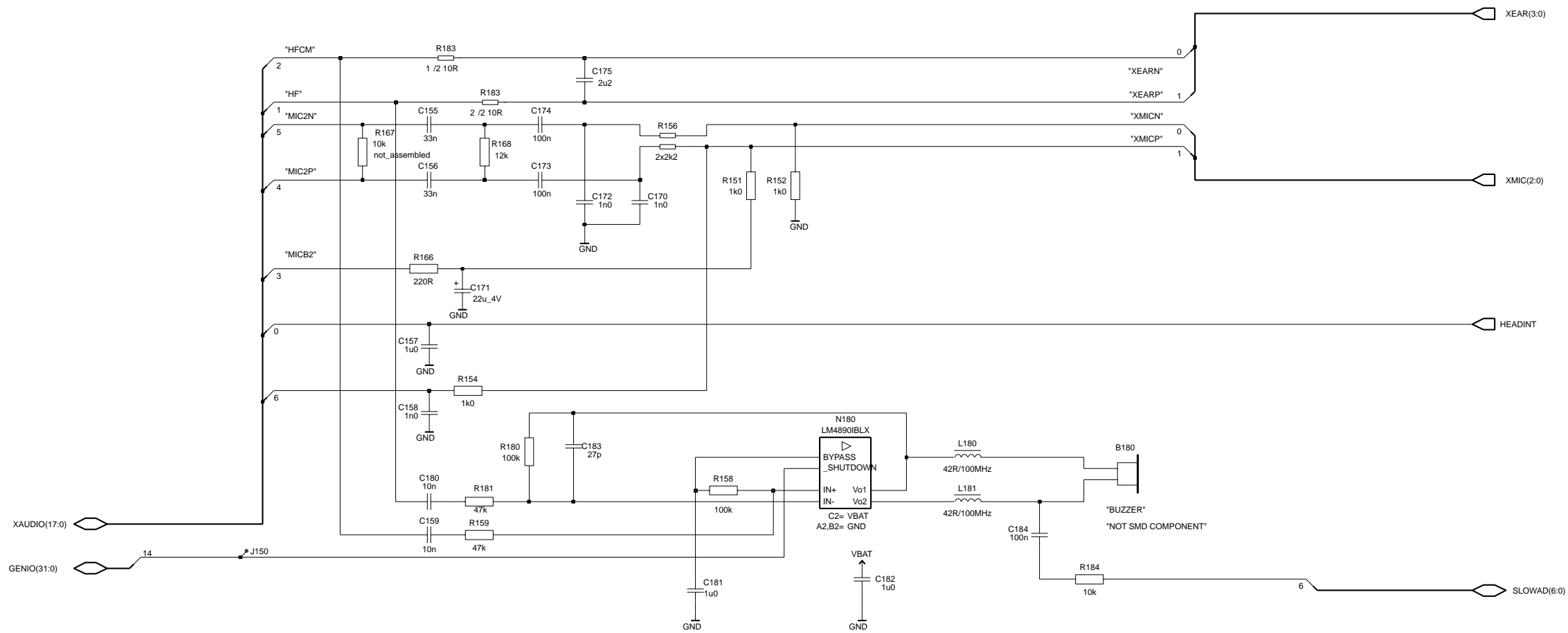
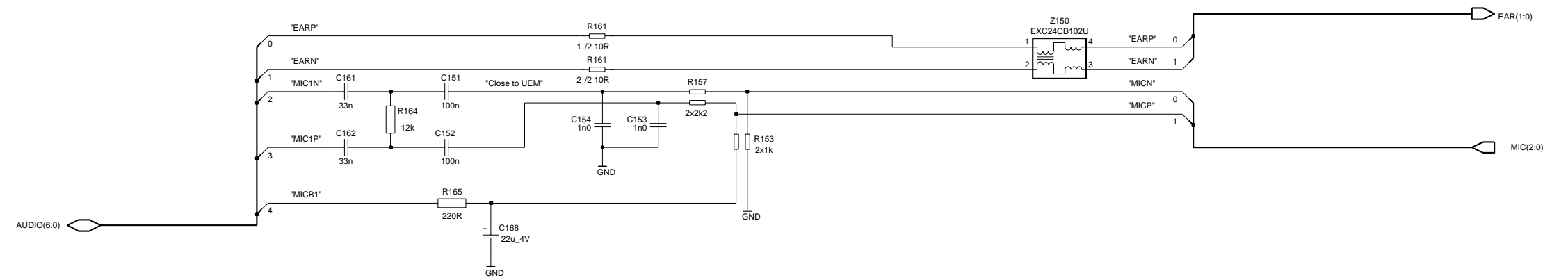



SIM Interface

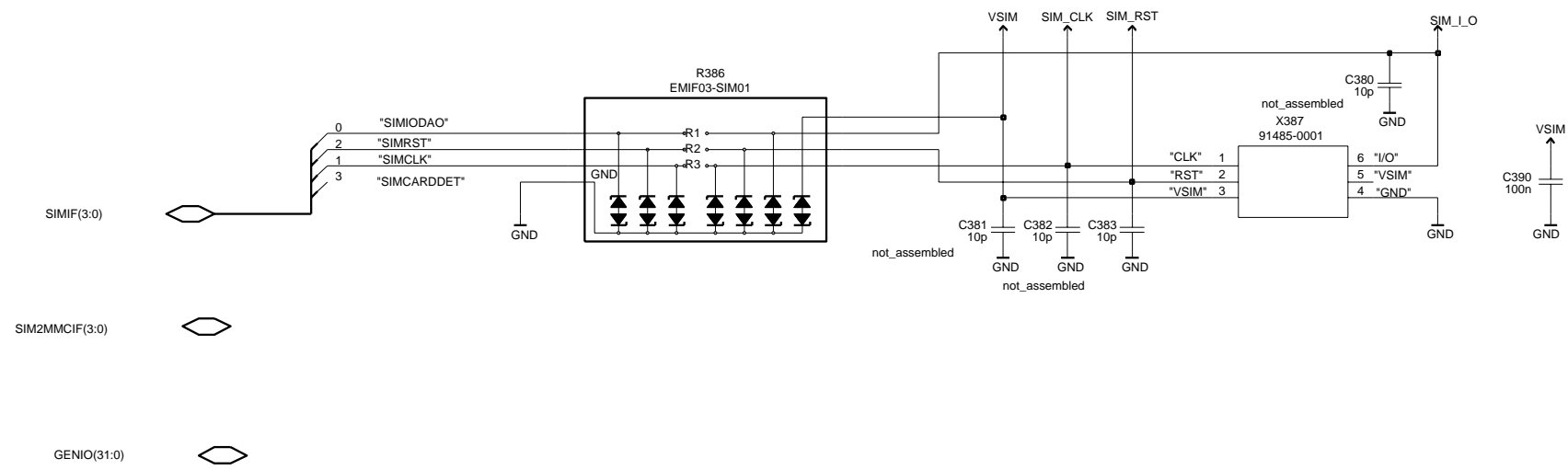

Power Amplifier

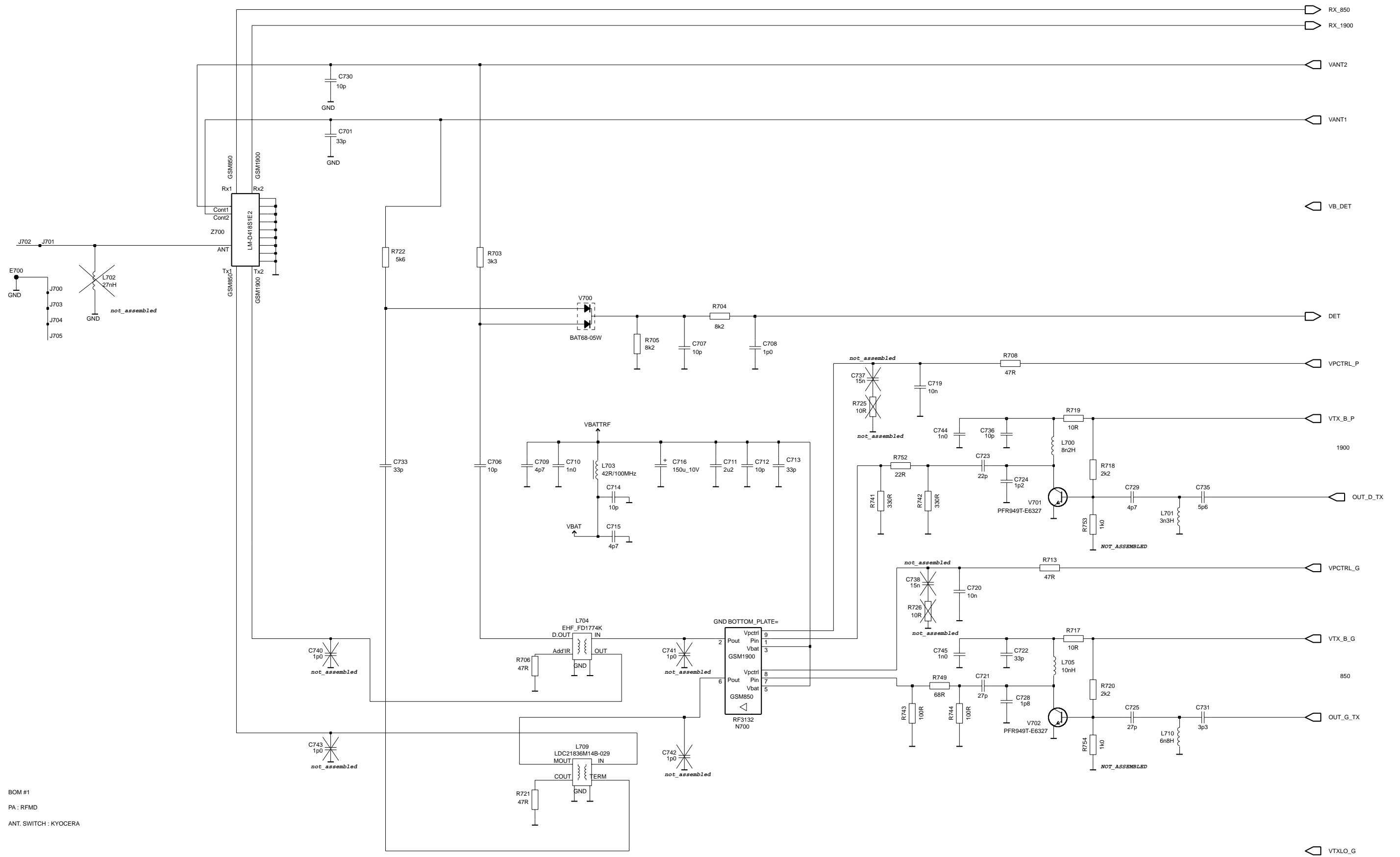

Mjoelner

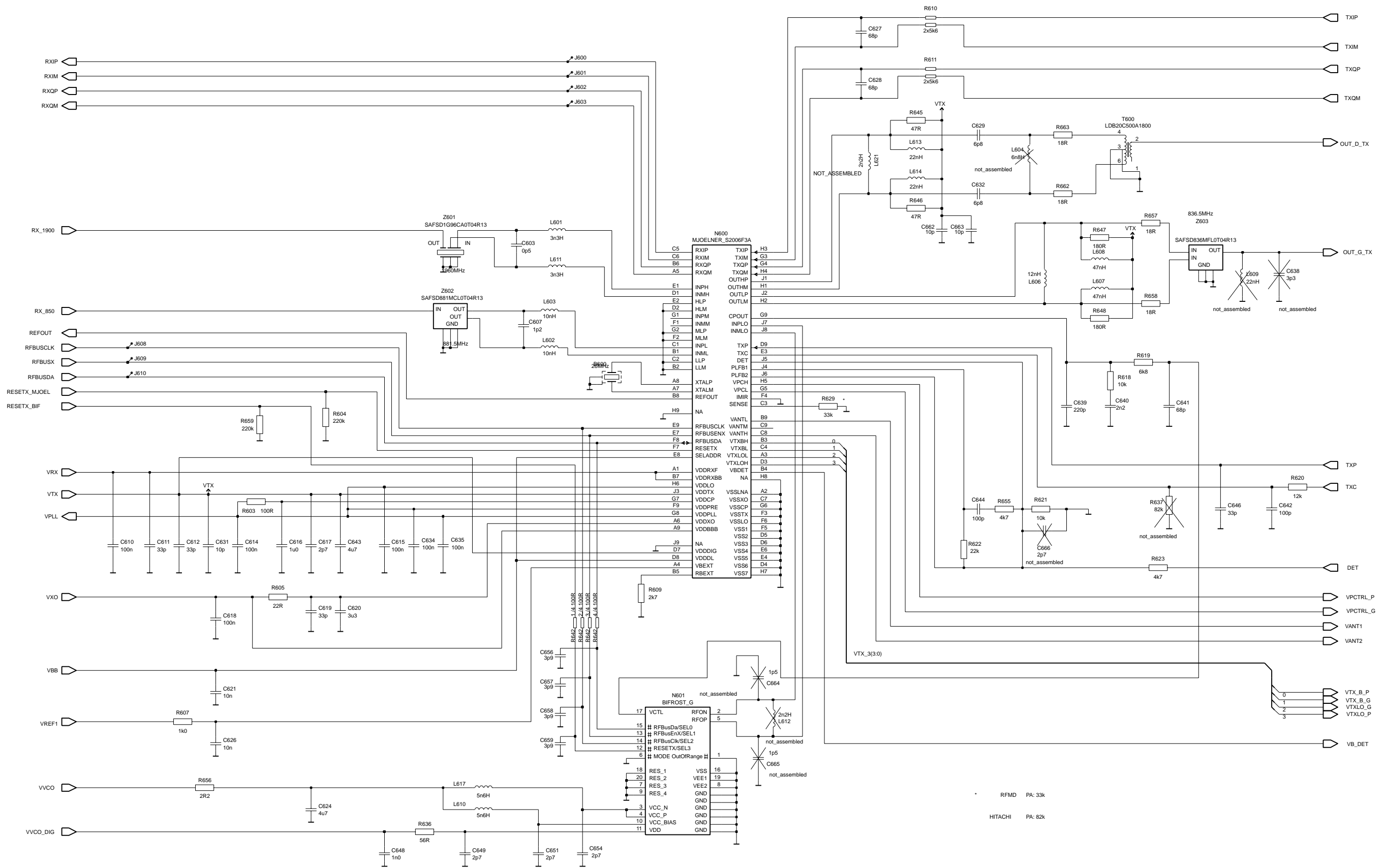

R603 - 663  
 C600 - 666  
 L600 - 621  
 Z600 - 603  
 J600 - 610  
 N600 - 601  
 B600  
 T600

RFMD PA: 33k  
 HITACHI PA: 82k

Component Layout - Top

